

## ECELCDG5VU

### Ultra Low Capacitance Array for ESD Protection

The ECELCDG5VU provides a typical line to line capacitance of 0.45pF and low insertion loss up to 3GHz providing greater signal integrity making it ideally suited for USB 3.0 applications, such as Digital TVs, DVD players, Computing, set-top boxes and MDDI applications in mobile computing devices.

It has been specifically designed to protect sensitive components which are connected to high-speed data and transmission lines from overvoltage caused by ESD(electrostatic discharge), CDE (Cable Discharge Events),and EFT (electrical fast transients).

### Features

- Protects four I/O lines
- Low capacitance
- Working voltages : 5V
- Low leakage current
- Low capacitance (<1.0pF) for high-speed interfaces
- No insertion loss to 3.0GHz
- Response Time is < 1 ns
- Meets MSL 1 Requirements
- Solid-state silicon avalanche technology
- ROHS compliant



**SOT-363**

### Main applications

- Digital Visual Interface (DVI)
- 10/100/1000 Ethernet
- USB 1.1/2.0/3.0/OTG
- IEEE 1394 Firewire Ports
- Projection TV Monitors and Flat Panel Displays
- Notebook Computers
- Set Top Box
- Projection TV

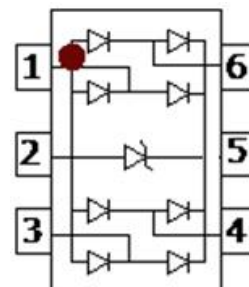

### Protection solution to meet

- IEC61000-4-2 (ESD) ±15kV (air), ±8kV (contact)
- IEC61000-4-4 (EFT) 40A (5/50ns)
- IEC61000-4-5 (Lightning) 5A (8/20µs)

### Ordering Information

Device	Qty per Reel	Reel Size
ECELCDG5VU	3000	7 Inch

<b>Maximum ratings (Temp=25°C Unless Otherwise Specified)</b>			
Parameter	Symbol	Value	Unit
Peak Pulse Power (tp=8/20μs waveform)	P <sub>PPP</sub>	50	Watts
Peak Pulse Current(tp=8/20μs waveform)	I <sub>PP</sub>	+5/-3	A
ESD Rating per IEC61000-4-2:	Contact	8	KV
	Air	15	
Lead Soldering Temperature	T <sub>L</sub>	260 (10 sec.)	°C
Operating Temperature Range	T <sub>J</sub>	-55 ~ 150	°C
Storage Temperature Range	T <sub>STG</sub>	-55 ~ 150	°C

Maximum ratings are those values beyond which device damage can occur. Maximum ratings applied to the device are individual stress limit values (not normal operating conditions) and are not valid simultaneously. If these limits are exceeded, device functional operation is not implied, damage may occur and reliability may be affected.

\*Other voltages may be available upon request.

1. Non-repetitive current pulse, per Figure 1.

<b>Electrical characteristics ( Temp=25°C Unless Otherwise Specified)</b>						
Symbol	Parameter	Conditions	Min.	Typ.	Max.	Units
V <sub>RWM</sub>	Reverse Working Voltage	Any I/O to Ground			5.0	V
V <sub>BR</sub>	Reverse Breakdown Voltage	I <sub>T</sub> = 1mA, Any I/O to Ground	6.0			V
I <sub>R</sub>	Reverse Leakage Current	V <sub>RWM</sub> = 5V Any I/O to Ground			1	μA
V <sub>F</sub>	Diode Forward Voltage	I <sub>F</sub> = 15mA		0.85	1.2	V
V <sub>C</sub>	Clamping Voltage	I <sub>PP</sub> = 1A, tp =8/20μs, any I/O pin to Ground			9.0	V
		I <sub>PP</sub> = 5A, tp =8/20μs, any I/O pin to Ground			13.0	V
I <sub>PP</sub>	Peak Pulse Current	tp =8/20μs			5	A
C <sub>J</sub>	Junction Capacitance	V <sub>R</sub> = 0V, f = 1MHz, between I/O pins		0.45	0.6	pF
		V <sub>R</sub> = 0V, f = 1MHz, any I/O pin to Ground		0.8	1.0	pF

Junction capacitance is measured in VR=0V,F=1MHz

Symbol	Parameter
V <sub>RWM</sub>	Working Peak Reverse Voltage
V <sub>BR</sub>	Breakdown Voltage @ I <sub>T</sub>
V <sub>C</sub>	Clamping Voltage @ I <sub>PP</sub>
I <sub>T</sub>	Test Current
I <sub>RM</sub>	Leakage current at V <sub>RWM</sub>
I <sub>PP</sub>	Peak pulse current
C <sub>O</sub>	Off-state Capacitance
C <sub>J</sub>	Junction Capacitance

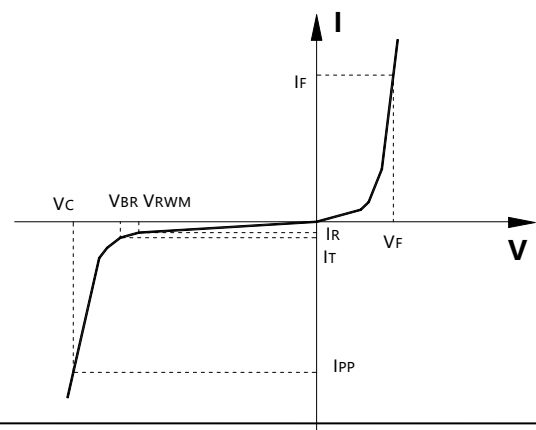

**Typical electrical characterist applications**

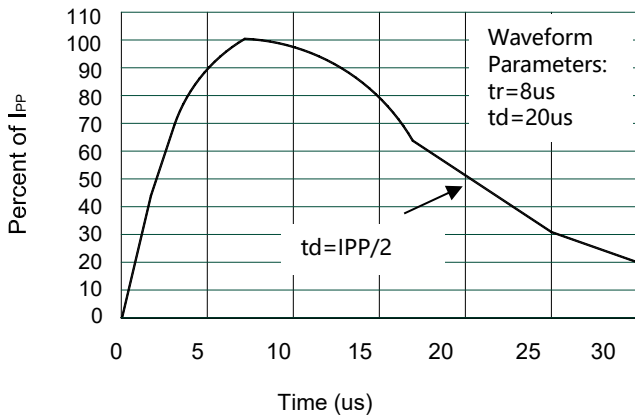

**Pulse Waveform**

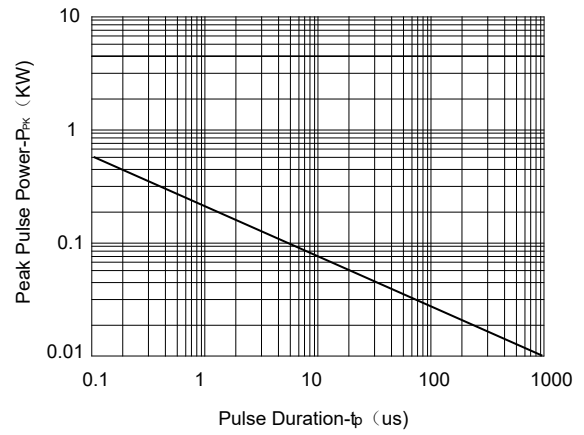

**Non-Repetitive Peak Pulse Power vs. Pulse Time**

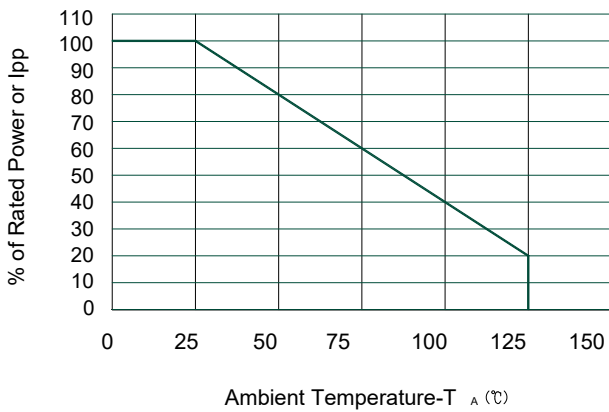

**Power Derating Curve**

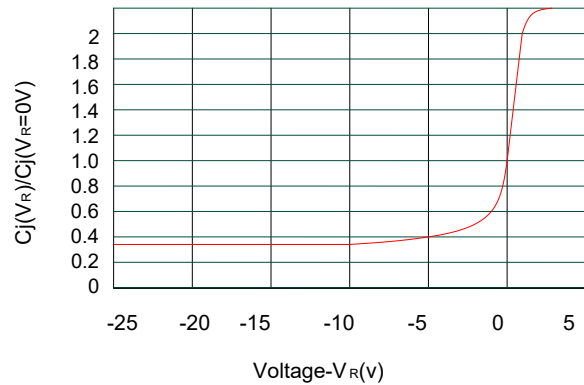

**Junction Capacitance vs. Reverse Voltage**

**Typical applications**

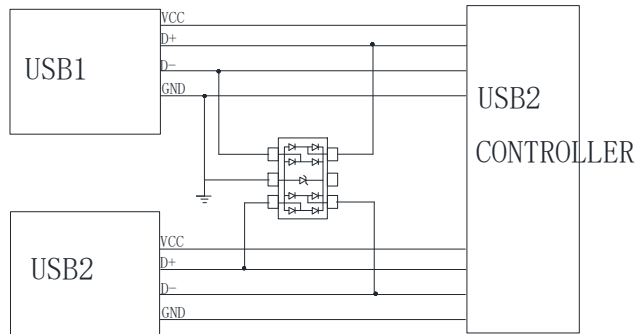

**DUAL USB PROTECTION FOR ESD**  
**ESD protection for USB port**

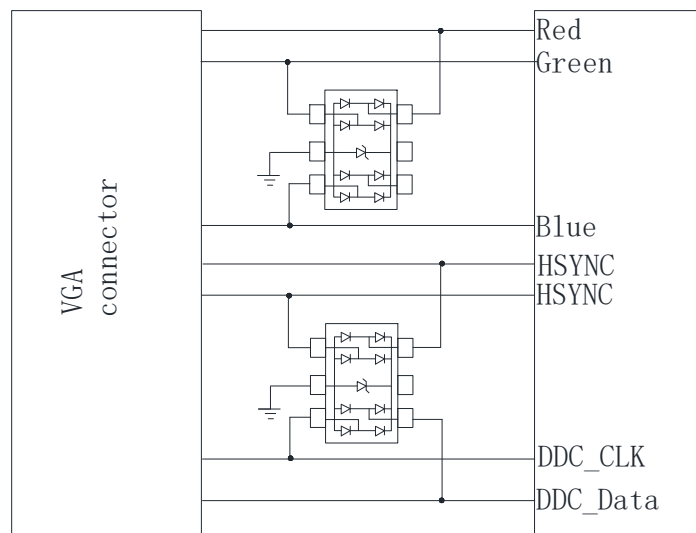

**ESD protection for VGA port**

**Package Information**

**SOT-363**

**Mechanical Data**

- Case: SOT-363
- Case Material: Molded Plastic. UL Flammability

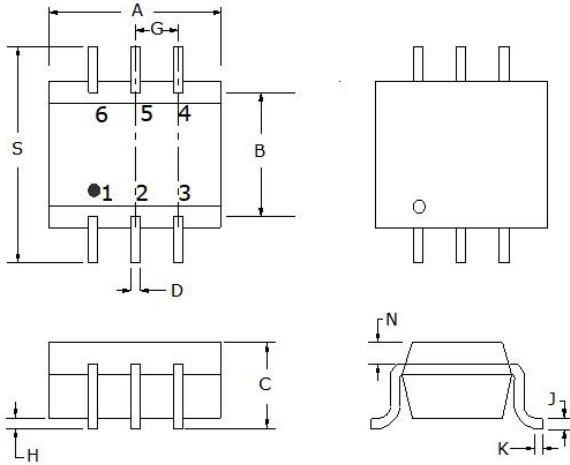

Dim	Millimeters		Inches	
	MIN	MAX	MIN	MAX
A	2.00	2.20	0.079	0.087
B	1.15	1.35	0.045	0.053
C	0.90	1.10	0.035	0.043
D	0.15	0.35	0.006	0.014
G	0.65BSC		0.026BSC	
H	--	0.10	--	0.004
J	0.08	0.15	0.003	0.006
K	0.15	0.35	0.006	0.014
N	0.20REF		0.008R EF	
S	2.15	2.45	0.085	0.096

**Recommended Pad outline**

