

P-Channel 30V(D-S) MOSFET

Product summary		
V_{DS}	-30	V
$R_{DS(ON)}$ (at $V_{GS}=-10V$) Typ.	16	m Ω
$R_{DS(ON)}$ (at $V_{GS}=-4.5V$) Typ.	24	m Ω
I_D ($T_C=25^\circ C$)	-10	A

Features

- High density cell design for low $R_{DS(ON)}$
- Trench Power LV MOSFET technology
- High Speed switching

Applications

- Power management functions
- Load switch

Pin Configuration

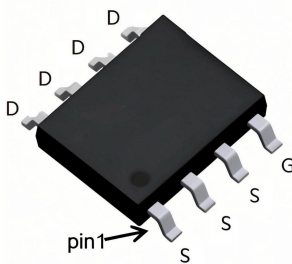

SOP8

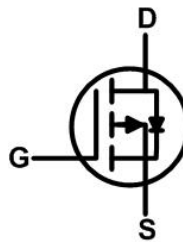

Packing Information

Device	Package	Reel Size	Quantity(Min. Package)
ECHA4435B	SOP8	13"	4000pcs

Absolute Maximum Ratings (at $T_A=25^\circ C$ Unless Otherwise Noted)

Symbol	Parameter	Rating	Units	
V_{DS}	Drain-Source Voltage	-30	V	
V_{GS}	Gate-Source Voltage	± 20	V	
I_D	Continuous Drain Current at $V_{GS}=10V^A$	$T_C=25^\circ C$	-10	A
		$T_C=100^\circ C$	-7	A
I_{DM}	Pulse Drain Current Tested ^B	-40	A	
P_D	Power Dissipation	3.3	W	
T_J, T_{STG}	Junction and Storage Temperature Range	-55 to +150	$^\circ C$	

Thermal Characteristics

Symbol	Parameter	Typical	Units
$R_{\theta JA}$	Thermal Resistance-Junction to ambient ^A	38	$^\circ C/W$

Electrical Characteristics (at $T_J = 25^\circ\text{C}$ Unless Otherwise Noted)

Symbol	Parameter	Condition	Min.	Typ.	Max.	Units
Static Parameters						
BV_{DSS}	Drain-Source Breakdown Voltage	$V_{GS}=0V, I_D=-250\mu A$	-30	--	--	V
I_{DSS}	Zero Gate Voltage Drain Current	$V_{DS}=-30V, V_{GS}=0V$	--	--	-1	μA
I_{GSS}	Gate-Body Leakage Current	$V_{DS}=0V, V_{GS}=\pm 20V$	--	--	± 100	nA
$V_{GS(th)}$	Gate Threshold Voltage	$V_{DS}=V_{GS}, I_D=-250\mu A$	-1.0	-1.5	-2.5	V
$R_{DS(on)}$	Drain-Source On-State Resistance ^B	$V_{GS}=-10V, I_D=-10A$	--	16	23	m Ω
		$V_{GS}=-4.5V, I_D=-5A$	--	24	34	m Ω
V_{SD}	Forward Voltage	$I_S=-10A, V_{GS}=0V$	--	--	-1.2	V
I_{SM}	Maximum Body-Diode Continuous Current		--	--	-10	A
Dynamic Parameters ^C						
C_{iss}	Input Capacitance	$V_{GS}=0V, V_{DS}=-15V$ $f=1MHz$	--	1488	--	pF
C_{oss}	Output Capacitance		--	315	--	pF
C_{riss}	Reverse Transfer Capacitance		--	275	--	pF
Q_g	Total Gate Charge	$V_{DS}=-15V, I_D=-9.1A$ $V_{GS}=-10V$	--	30.3	--	nC
Q_{gs}	Gate-Source Charge		--	5.5	--	nC
Q_{gd}	Gate-Drain Charge		--	7.6	--	nC
$t_{D(on)}$	Turn-on Delay Time	$V_{DD}=-15V$ $I_D=-6A, R_G=2.5\Omega,$ $V_{GS}=-10V$	--	14.6	--	nS
t_r	Turn-on Rise Time		--	19.7	--	nS
$t_{D(off)}$	Turn-off Delay Time		--	95	--	nS
t_f	Turn-off Fall Time		--	64	--	nS

A. The data tested by surface mounted on a 1 inch² FR-4 board with 2OZ copper.

B. The data tested by pulsed , pulse width $\leq 300\mu s$, duty cycle $\leq 2\%$.

C. Guaranteed by design, not subject to production testing.

Typical Characteristics

Figure 1: Output Characteristics

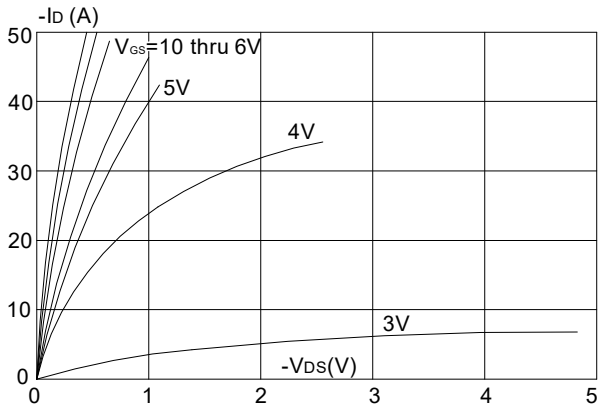

Figure 2: Typical Transfer Characteristics

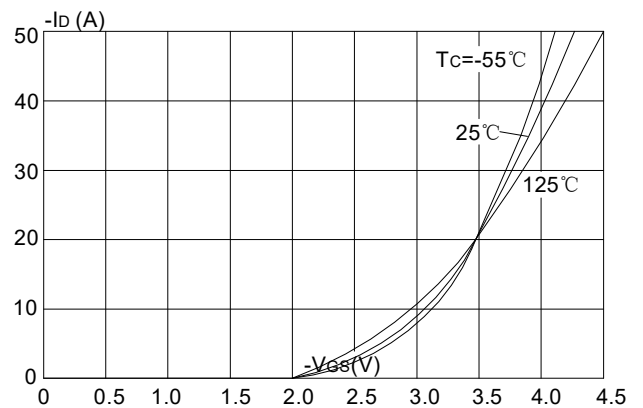

Figure 3: On-resistance vs. Drain Current

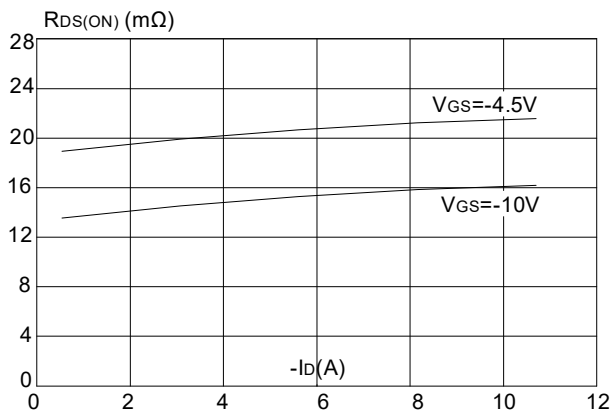

Figure 4: Body Diode Characteristics

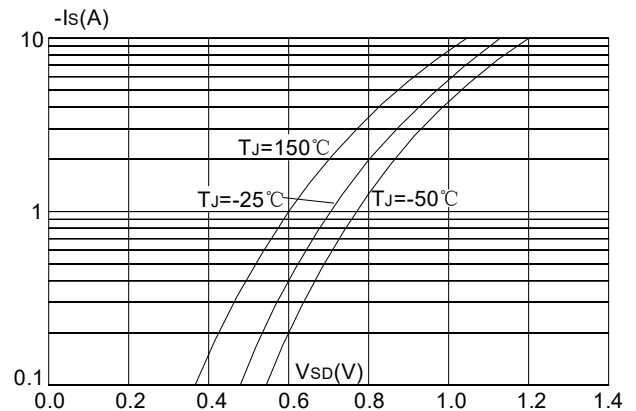

Figure 5: Gate Charge Characteristics

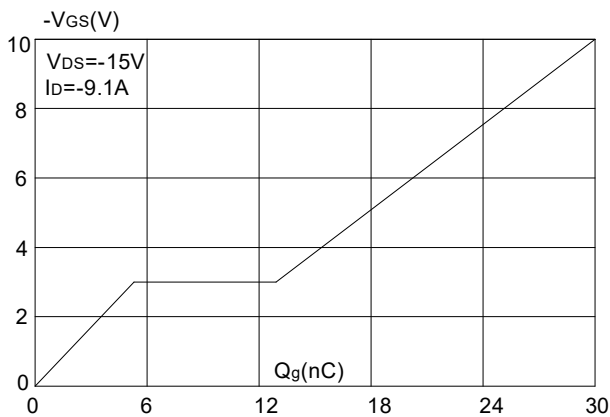
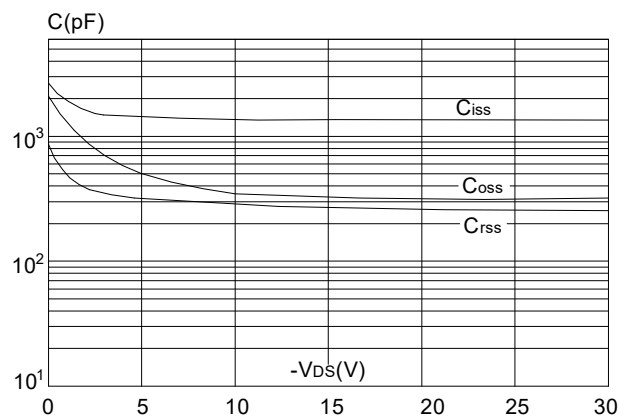

Figure 6: Capacitance Characteristics



Typical Characteristics

Figure 7: Normalized Breakdown Voltage vs. Junction Temperature

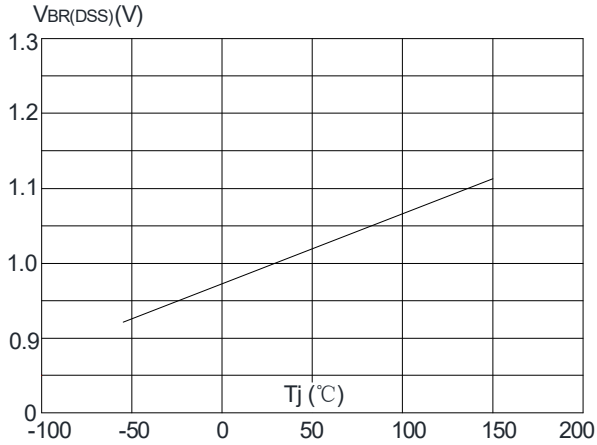

Figure 8: Normalized on Resistance vs. Junction Temperature

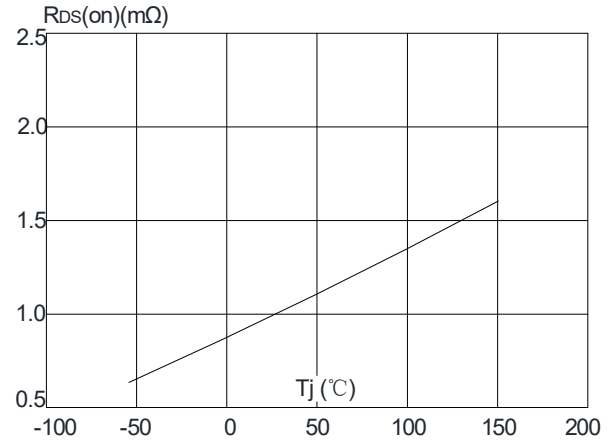

Figure 9: Maximum Safe Operating Area

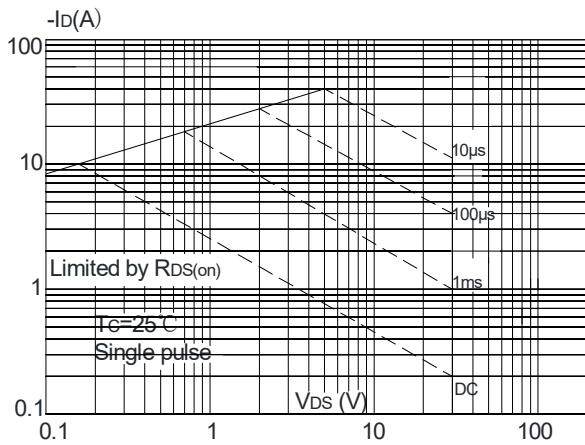

Figure 10: Maximum Continuous Drain Current vs. Case Temperature

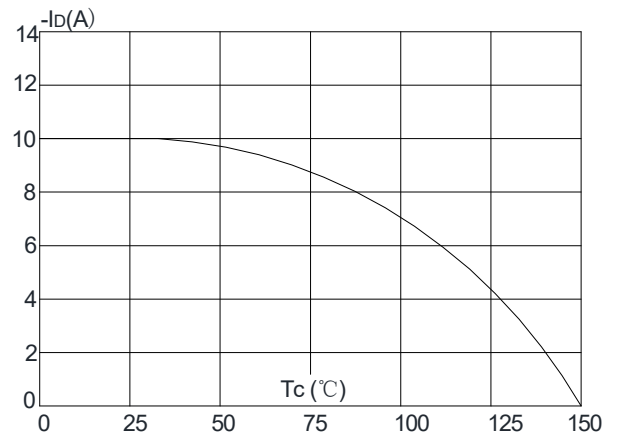
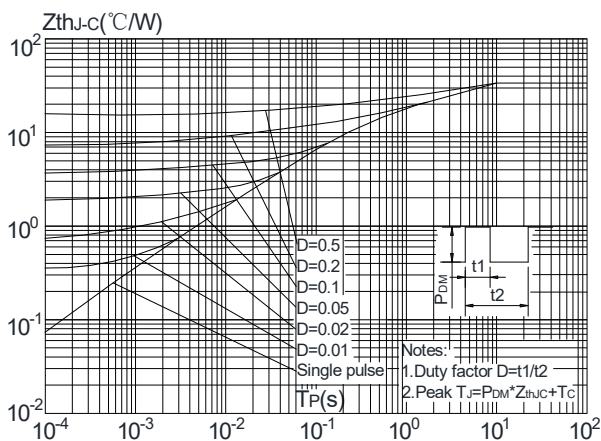
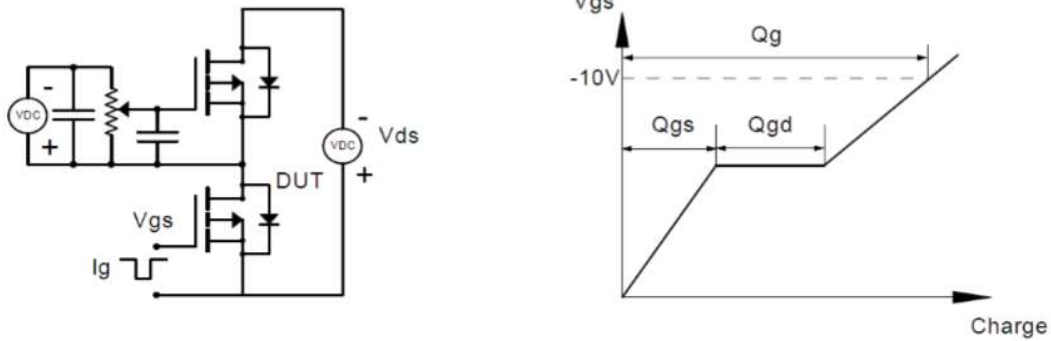

Figure.11: Maximum Effective Transient Thermal Impedance, Junction-to-Ambient



Test Circuit

Gate Charge Test Circuit & Waveform



Resistive Switching Test Circuit & Waveforms

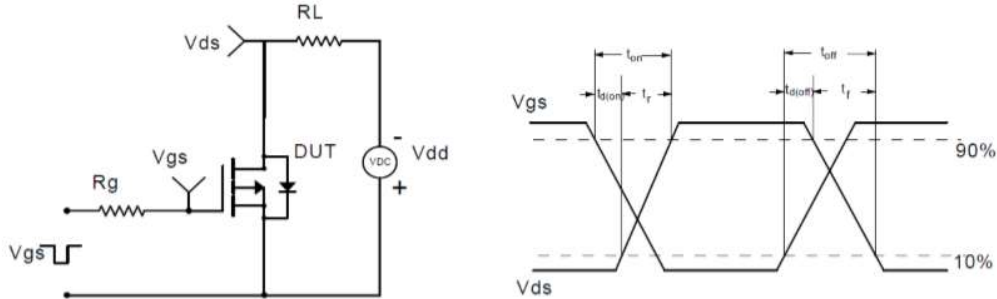

Unclamped Inductive Switching (UIS) Test Circuit & Waveforms

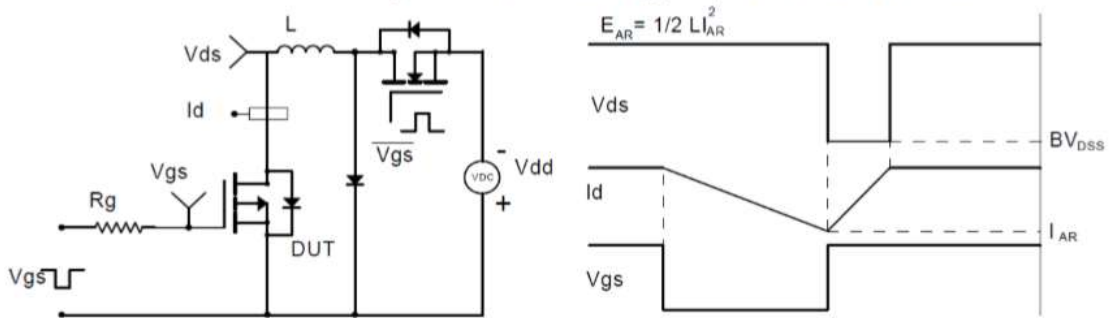

Diode Recovery Test Circuit & Waveforms

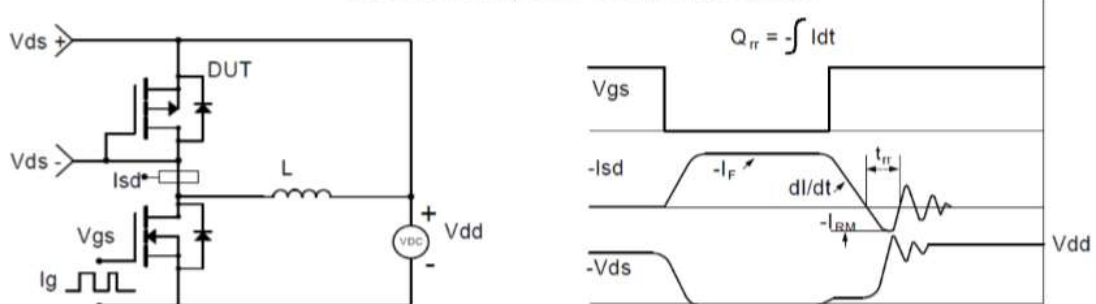

SOP8 Package Information

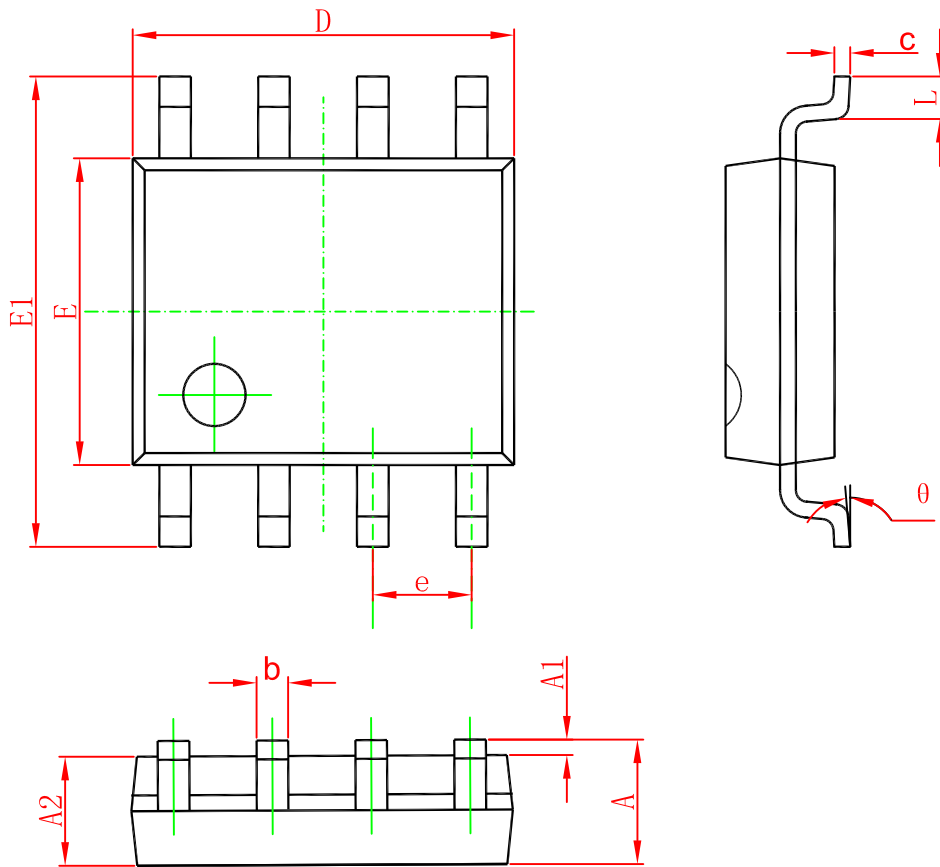

Symbol	Dimensions In Millimeters		Dimensions In Inches	
	Min	Max	Min	Max
A	1.350	1.750	0.053	0.069
A1	0.100	0.250	0.004	0.010
A2	1.350	1.550	0.053	0.061
b	0.330	0.510	0.013	0.020
c	0.170	0.250	0.006	0.010
D	4.700	5.100	0.185	0.200
E	3.800	4.000	0.150	0.157
E1	5.800	6.200	0.228	0.244
e	1.270 (BSC)		0.050 (BSC)	
L	0.400	1.270	0.016	0.050
θ	0°	8°	0°	8°