

N-Channel 68V(D-S) MOSFET

Product summary		
V_{DS}	68	V
$R_{DS(ON)}$ (at $V_{GS}=10V$) Typ.	6.5	m Ω
I_D ($T_C=25^\circ C$)	80	A

Features

- High density cell design for low $R_{DS(ON)}$
- Fast switching

Applications

- PWM Application
- Load switching

Pin Configuration



TO-252

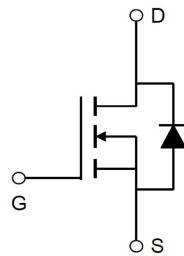

Packing Information

Device	Package	Reel Size	Quantity(Min. Package)
ECFA80N07	TO-252	13"	2500pcs

Absolute Maximum Ratings (at $T_A=25^\circ C$ Unless Otherwise Noted)

Symbol	Parameter	Rating	Units
V_{DS}	Drain-Source Voltage	68	V
V_{GS}	Gate-Source Voltage	± 25	V
I_D	Continuous Drain Current	$T_C=25^\circ C$	80
		$T_C=100^\circ C$	51
I_{DM}	Pulse Drain Current Tested ^A	320	A
E_{AS}	Single Pulse Avalanche Energy ^B	260	mJ
P_D	Power Dissipation $T_C=25^\circ C$	125	W
T_J, T_{STG}	Junction and Storage Temperature Range	-55 to +150	$^\circ C$

Thermal Characteristics

Symbol	Parameter	Typical	Units
$R_{\theta JC}$	Thermal Resistance-Junction to case	1.0	$^\circ C/W$

Electrical Characteristics (at $T_J = 25^\circ\text{C}$ Unless Otherwise Noted)

Symbol	Parameter	Condition	Min.	Typ.	Max.	Units
Static Parameters						
BV_{DSS}	Drain-Source Breakdown Voltage	$V_{GS}=0V, I_D=250\mu A$	68	--	--	V
I_{DSS}	Zero Gate Voltage Drain Current	$V_{DS}=68V, V_{GS}=0V$	--	--	1	μA
I_{GSS}	Gate-Body Leakage Current	$V_{DS}=0V, V_{GS}=\pm 25V$	--	--	± 100	nA
$V_{GS(th)}$	Gate Threshold Voltage	$V_{DS}=V_{GS}, I_D=250\mu A$	2.0	3.0	4.0	V
$R_{DS(ON)}$	Drain-Source On-State Resistance ^C	$V_{GS}=10V, I_D=20A$	--	6.5	8.5	m Ω
V_{SD}	Forward Voltage	$I_S=20A, V_{GS}=0V$	--	--	1.2	V
I_S	Maximum Body-Diode Continuous Current		--	--	80	A
Dynamic Parameters ^D						
C_{iss}	Input Capacitance	$V_{GS}=0V, V_{DS}=35V$ $f=1\text{MHz}$	--	5800	--	pF
C_{oss}	Output Capacitance		--	220	--	pF
C_{rss}	Reverse Transfer Capacitance		--	210	--	pF
Q_g	Total Gate Charge	$V_{DS}=60V, I_D=40A$ $V_{GS}=10V$	--	92	--	nC
Q_{gs}	Gate-Source Charge		--	23	--	nC
Q_{gd}	Gate-Drain Charge		--	35	--	nC
$t_{D(on)}$	Turn-on Delay Time	$V_{DS}=35V, I_D=40A,$ $R_L=3\Omega,$ $V_{GS}=10V$	--	23	--	ns
t_r	Turn-on Rise Time		--	22	--	ns
$t_{D(off)}$	Turn-off Delay Time		--	46	--	ns
t_f	Turn-off Fall Time		--	9	--	ns

A. Repetitive Rating: Pulse Width Limited by Maximum Junction Temperature.

B. EAS condition: $T_J=25^\circ\text{C}$, $V_{DD}=50V$, $V_G=10V$, $L=0.5\text{mH}$.

C. Pulse Test: Pulse Width $\leq 300\mu s$, Duty cycle $\leq 2\%$.

D. Guaranteed by design, not subject to production testing.

Typical Characteristics

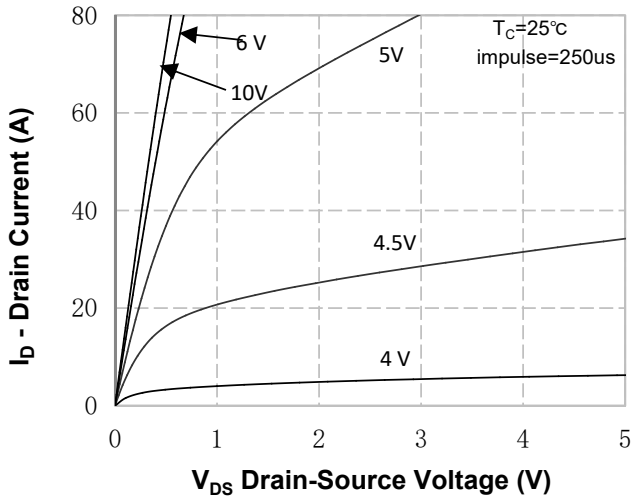

Figure 1. On-Region Characteristics

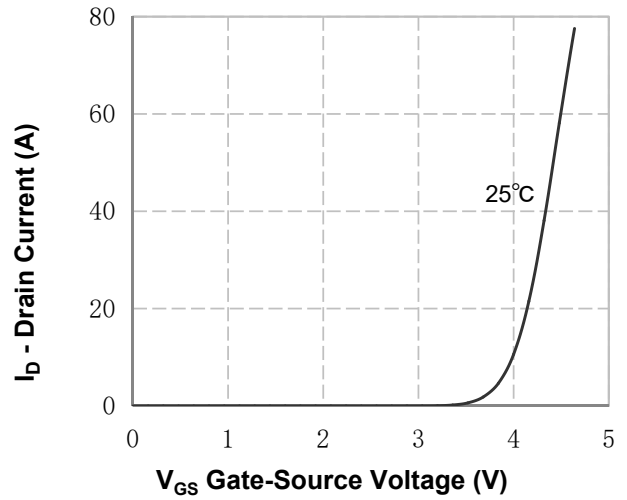

Figure 2. Transfer Characteristics

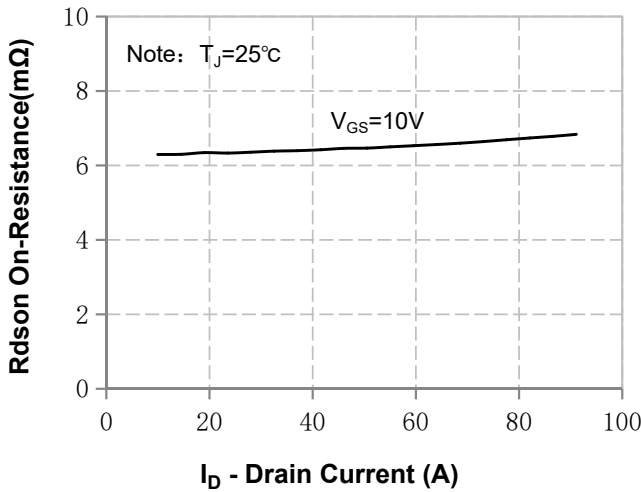

Figure 3. On-Resistance Variation vs Drain Current and Gate Voltage

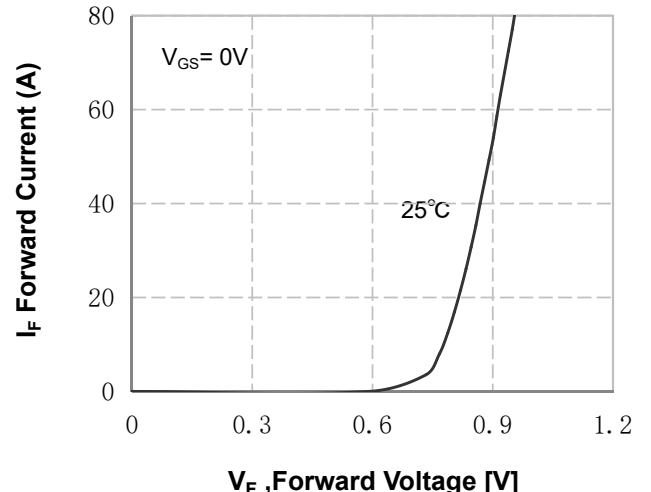

Figure 4. Body Diode Forward Voltage Variation vs Source Current

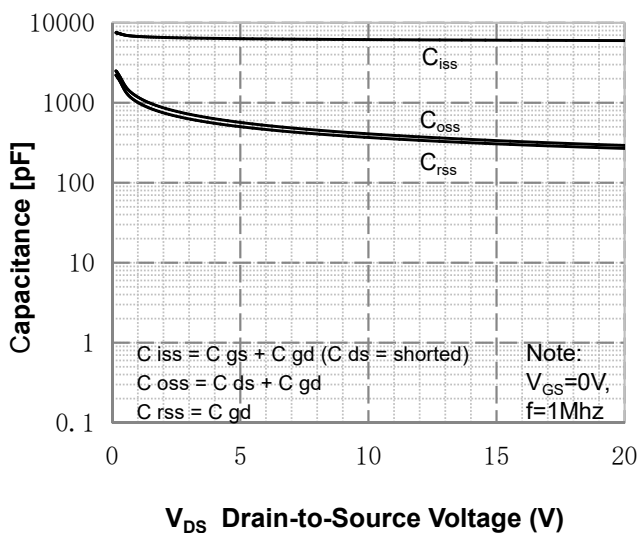

Figure 5. Capacitance Characteristics

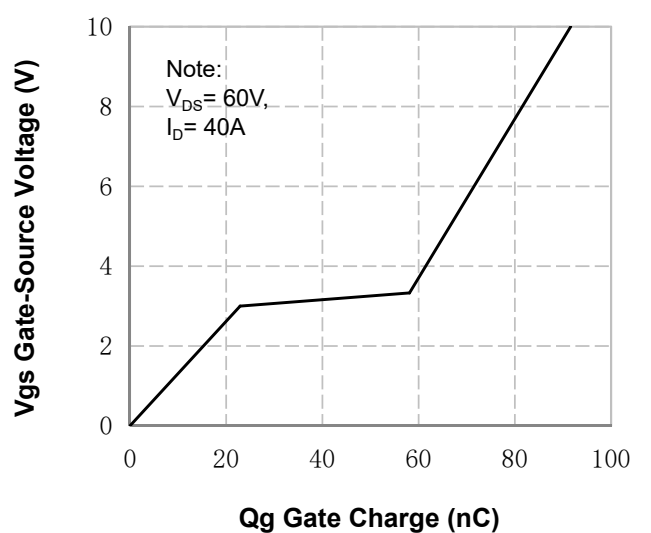

Figure 6. Gate Charge Characteristics

Typical Characteristics

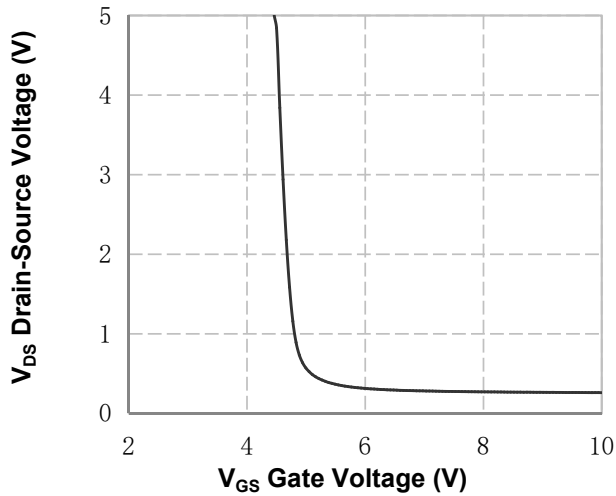

Figure 7. Vds Drain-Source Voltage vs Gate Voltage

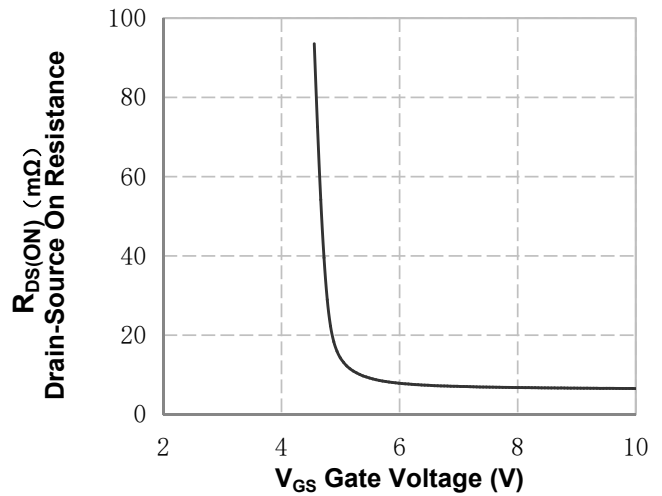

Figure 8. On-Resistance vs Gate Voltage

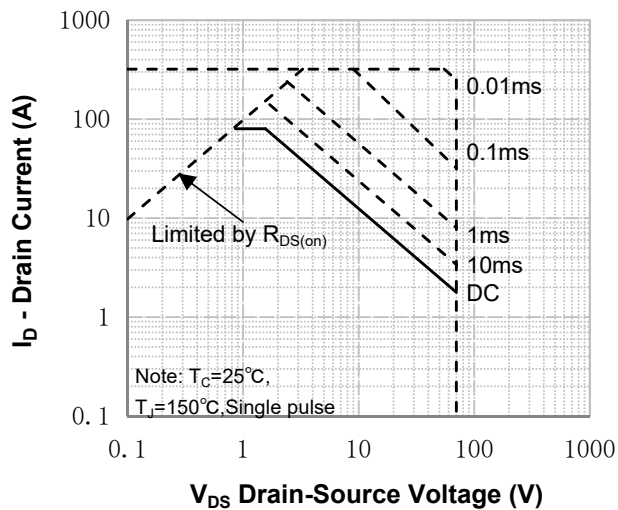

Figure 9. Maximum Safe Operating Area

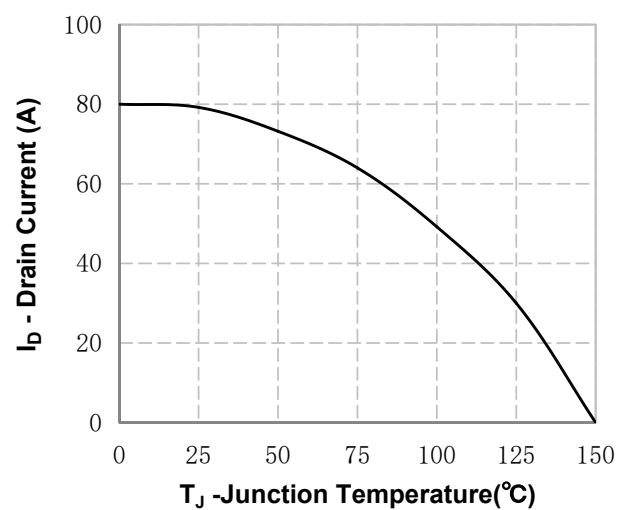

Figure 10. Maximum Continuous Drain Current vs Temperature

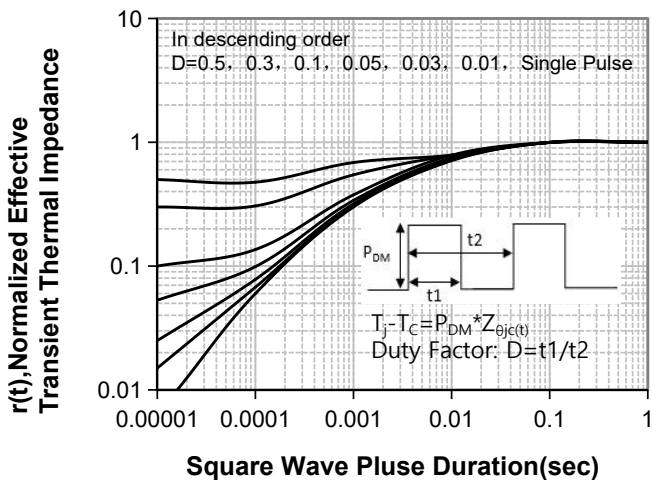
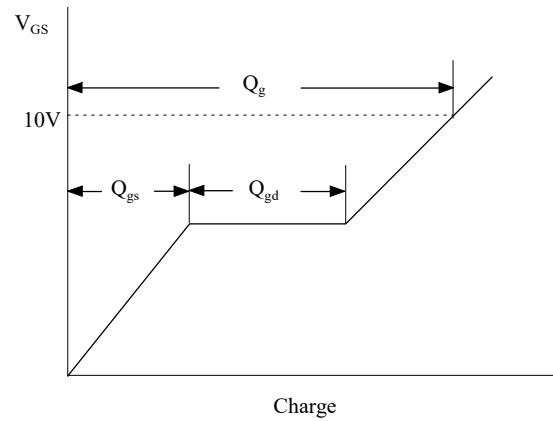
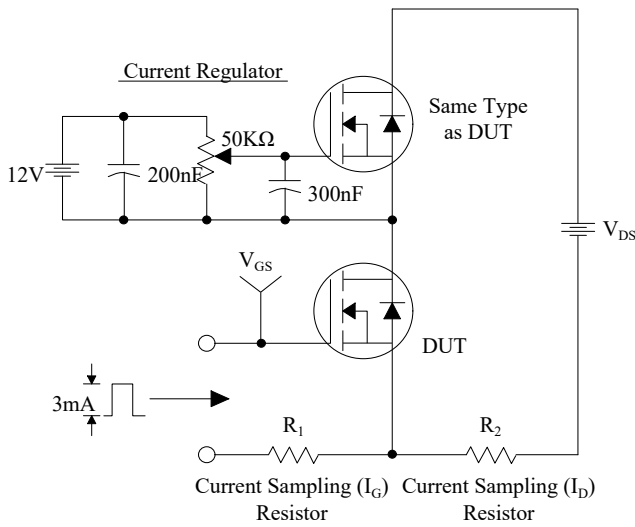

Figure 11. Transient Thermal Response Curve

Test Circuit

Gate Charge Test Circuit & Waveform



Resistive Switching Test Circuit & Waveforms

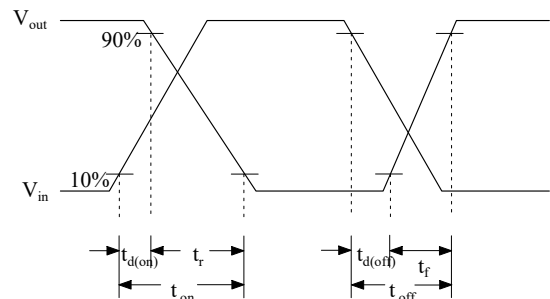
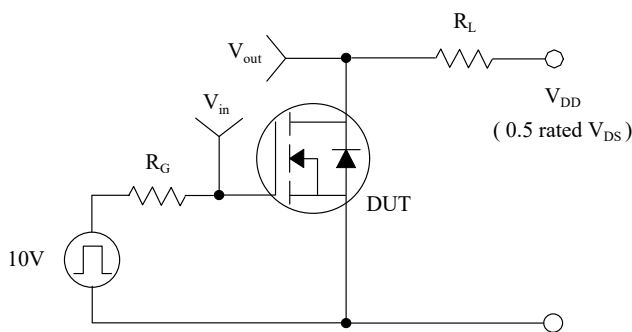

Unclamped Inductive Switching Test Circuit & Waveforms

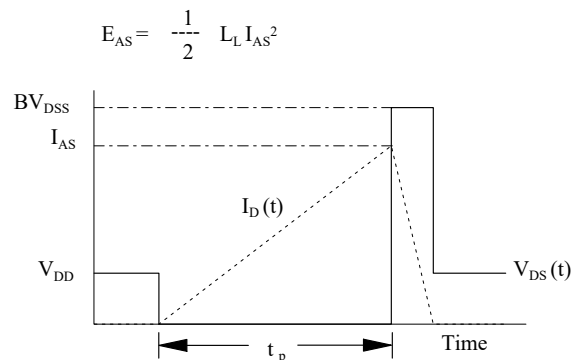
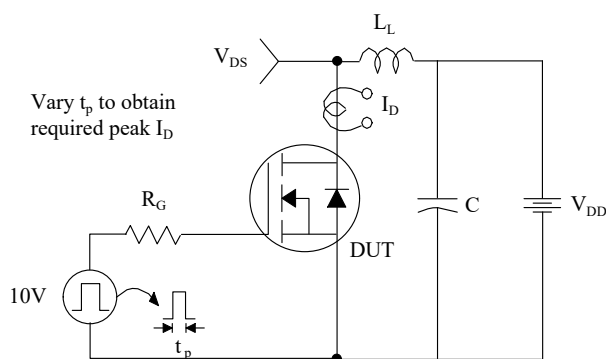

Test Circuit

Peak Diode Recovery dv/dt Test Circuit & Waveforms

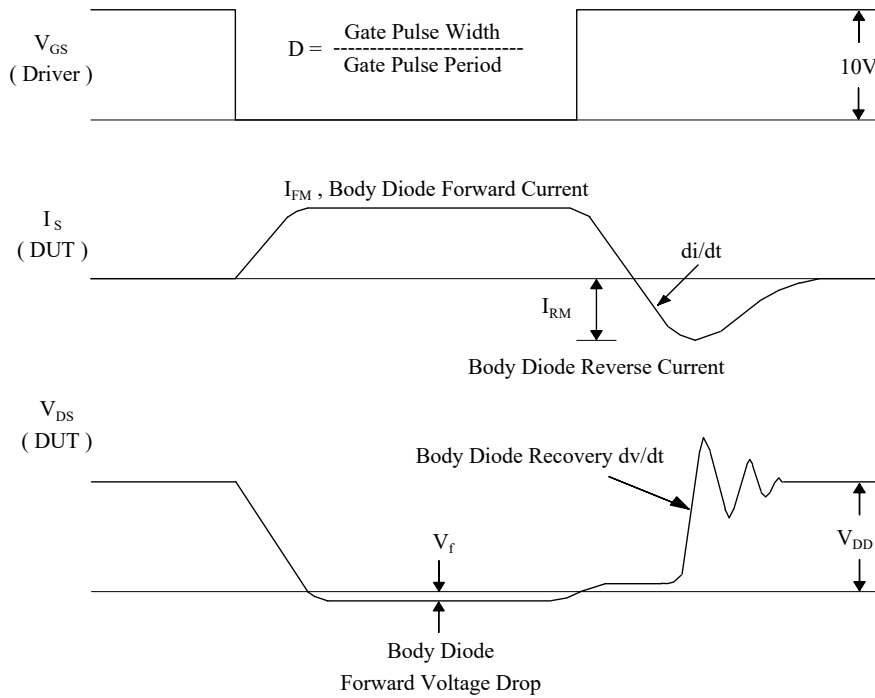
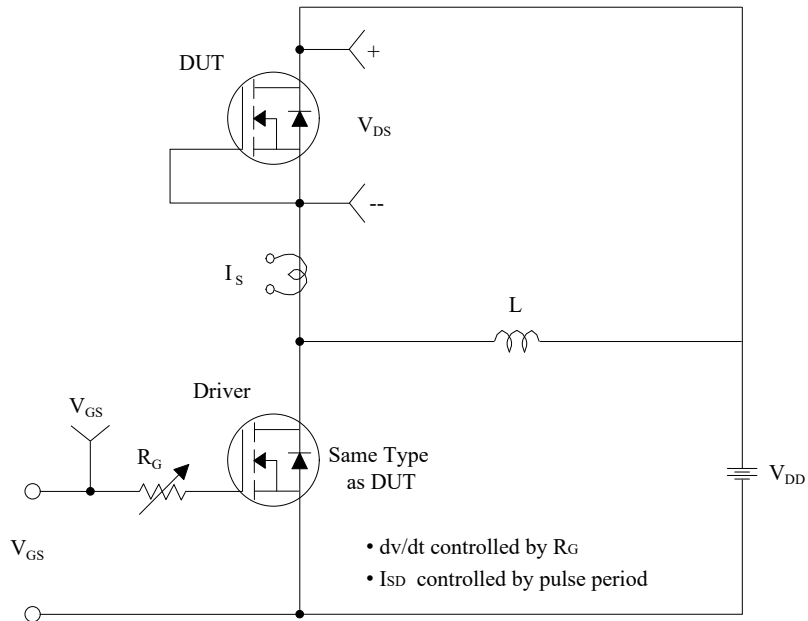

TO-252 Package Information

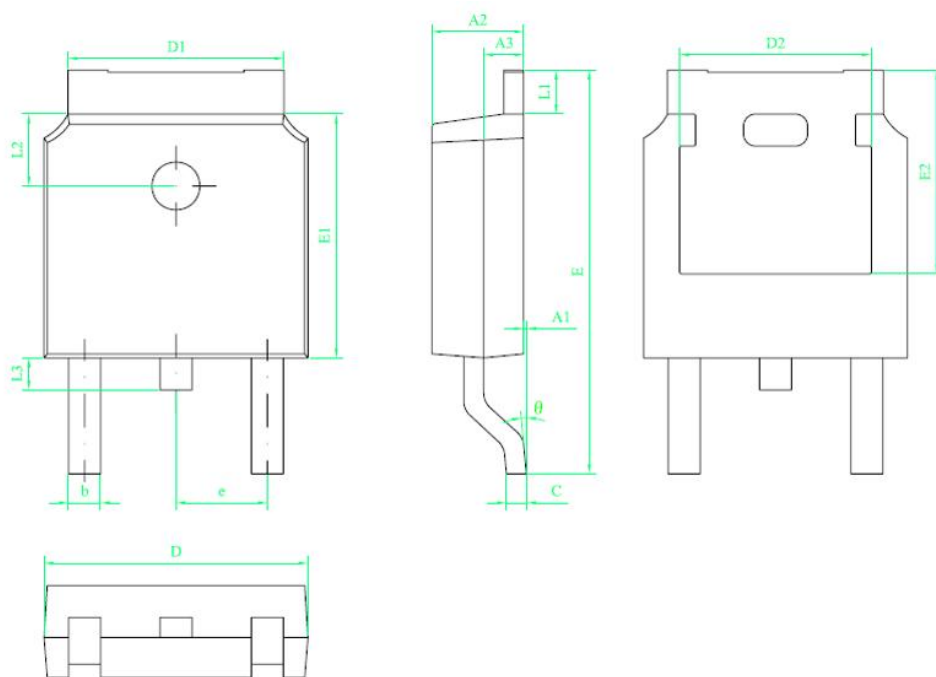

符号	尺寸		
	min	nom	max
A1	0	---	0.10
A2	2.20	2.30	2.40
A3	0.90	1.00	1.10
b	0.75	---	0.85
c	0.50	---	0.60
D	6.50	6.60	6.70
D1	5.30	5.40	5.50
D2	4.70	4.80	4.90
E	9.90	10.10	10.30
E1	6.00	6.10	6.20
E2	5.20	5.30	5.40
e	2.20	2.286	2.40
L1	0.90	---	1.25
L2	1.70	1.80	1.90
L3	0.60	0.80	1.00
θ	0°	---	8°

技术要求:

1. 树脂体不应有崩裂、缺损等缺陷;
2. 树脂上下部X、Y方向偏差不得超过0.20;
3. 胶体两端留胶总宽度和宽度不超过0.50;
4. 所有单位为mm;